



2011
WAKEBOARD UK
RULES

INDEX

1 General Information 3
2 Categories 4
3 Running Order & Heat System 5
4 Equipment 6
5 Re-Rides 7
6 Protests 7
7 Use of Video 8
8 Competition Format 8
9 Wakeboard Course 9
10 Double-Up 10
11 Obstacles 10
12 Boat Speed & Rope Length 12
13 Falls 12
14 Homologation 13
15 Registration 14
16 Officials 14



GENERAL INFORMATION

1.1 Applicability of the Rules

The rules set forth here govern wakeboard competitions sanctioned by Wakeboard UK, which is part of British Waterski & Wakeboard

These Wakeboard UK Rules are supplementary to the IWWF E&A Additional Rules Wakeboard Boat Rules and the general IWWF E&A regulations including the Bye-Laws, Rules of Eligibility, Anti-Doping Policy, Letter of Agreement and Obligations for Titled Events, and Guidelines. In case of conflict between a regulation in these Additional Rules and a general IWWF E&A regulation, the latter shall apply. The general IWWF E&A regulations are of significance for organizers of, as well as judges and riders at wakeboard events, and must be considered.

1.2 Variations from the IWWF Technical Rules

The Wakeboard UK Rules may make variations from the Technical Rules that do not affect the recorded scores of the competition or the homologation of the competition. Examples of acceptable variations are those to entry requirements, familiarization, method of draw, number of events or rounds, number in finals, method of determining event placement and/or overall and team placement.

1.3 Exceptions to the Rules

Where compliance with the rules is not feasible, the Chief Judge shall with the approval of the majority of the Judges, make the necessary changes. Such changes will be announced at a rider's meeting, and by posting. The Chief Judge shall send a report to the Wakeboard Council to explain these changes to the rules. Where the rules are definite and feasible, a vote of the Judges to decide whether to enforce any provision is prohibited.

1.4 Drug Testing

All competitors must agree to be subject to doping control. Specific policies and procedures regarding doping control shall be detailed in the Medical Regulations of the International Waterski & Wakeboard Federation.

1.5 Unsportsmanlike Conduct

Any rider or official whose conduct is deemed unsportsmanlike or whose conduct may cause discredit to the Wakeboard UK and IWWF, either on or off the competition site, before, during, or after the competition, may be disqualified (rider) or banned (official) from all the competition including completed events.

Unsportsmanlike conduct includes, but is not limited to: use of vulgar language in public, public tantrums, not riding to fullest potential, failure to attend designated functions or events, consuming alcoholic beverages during the competition, competing under false pretences, concealing significant injuries or health problems, or criticize judges' scores.

1.6 Unsafe Rider Disqualification

No rider shall be allowed to compete or to continue to compete if, in the opinion of the Chief Judge or Safety Director and a majority of the judges, his competing would be a danger to himself or other riders in the competition.

During the competition at any time the Chief Judge may, or the Safety Director may request the Chief Judge to, halt the competition for a poll of the judges in regard to a rider's actions or conditions. Whenever practical, the advice of a doctor should be obtained.

1.7 Discharge of Liability

On each national or international event, all competitors, or if the rider is under 18 years of age its parent or team captain, must sign a discharge of liability for the organizer and the host federation in case of accident, material damages, or moral or physical tort, in the domain of the competition. All organizations, federations, persons or institutions involved in the organization of an event who encounter an illicit deed of a competitor, are obligated to use the local Constabulary or judicial authorities in order to judge all litigations and charges against the competitor. A copy of the filed report shall be forwarded to his own federation who will prohibit the competitor's access to all events as long as the litigations are not definitely settled.

1.8 Suggestions

Riders are encouraged to bring up suggestions and questions of their concern to any judge or to the Wakeboard UK Committee in any way possible. Contact information to officials and members of the Council is available on the Council's website at www.wakeboard.co.uk. Suggestions regarding these rules must be brought up before November 1st for changes of the rules for the following year.

2 CATEGORIES

The Chief Judge with the approval of the majority of the judges may open a category with less than six riders.

A rider's age as of 1st. of January the current year will be used to determine age bracket.

Youth Nationals

2.1 Youngsters (Boys & Girls)

9 years old and under. If a rider was born in the following years, then they qualify for this category:

If a rider was born in 2001 and after.

2.2 Boys

10 to 14 years old. If a rider was born in the following years, then they qualify for this category:

2000 - 1999 - 1998 - 1997 - 1996

2.3 Girls

10 to 14 years old. If a rider was born in the following years, then they qualify for this category:

2000 - 1999 - 1998 - 1997 - 1996

2.4 Junior Men

15 to 18 years old. If a rider was born in the following years, then they qualify for this category:

1995 - 1994 - 1993 - 1992

2.5 Junior Ladies

15 to 18 years old. If a rider was born in the following years, then they qualify for this category:

1995 - 1994 - 1993 – 1992

Open Nationals

2.6 Open Division – Men

No age restriction.

Open Division – Men 2

No age restriction,

Note : This category does not produce E&A Wakeboard Ranking points

2.7 Open Division - Ladies

No age restriction.

2.8 Masters - Men

30 years old and over: If a rider was born in 1980 and before.

2.9 Masters - Ladies

30 years old and over: If a rider was born in 1980 and before.

2.10 Masters 2 - Men

39 years old and over: If a rider was born in 1971 and before.

This category can only be opened if there are enough riders to open both Master - Men and Masters 2 - Men.

2.11 Masters 2 - Ladies

39 years old and over: If a rider was born in 1971 and before.

This category can only be opened if there are enough riders to open both Master - Ladies and Masters 2 - Ladies.

3 RUNNING ORDER & HEAT SYSTEM

3.1 General

Wakeboard competitions will use a heat system.

3.2 Qualification Rounds

In qualifying rounds, the running order will be randomly determined by numbered ping pong balls or by a similar system. The number of riders in each heat is dependent on the total number of riders entered. A percentage of the riders from each heat will then go through to the, semi-finals and finals depending on numbers.

3.3 Running of the Competition

A rider will be disqualified from all the competition if he fails to be on hand and ready to ride with an untangled rope when the boat is prepared to start. That means when the rope is fixed and the boat starts to be in line with the course. Should a rider be disqualified for any reason, he will not be permitted to participate in the remainder of the competition, i.e. if he misses his turn in the qualifying rounds, he will not be permitted to compete in the last chance qualifiers (LCQ).

In the case where a rider is not available or has been disqualified, a one-minute delay shall be granted to the next rider in the starting order if he was not on the starting jetty at the time of disqualification. If more than one rider has been disqualified, the time allotted to the next rider shall be one minute for each rider disqualified.

Simplified examples:

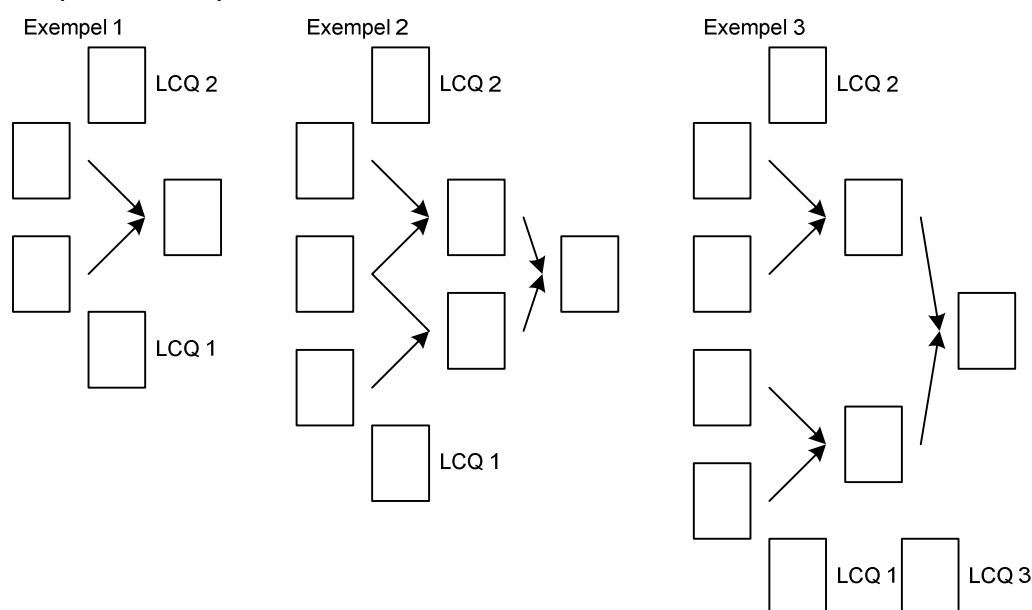

4 EQUIPMENT

4.1 General

All personal equipment is subject to the approval of the Chief Judge and Safety Director, named at each event.

4.2 Life Vest

All competitors must wear a life vest. It is responsibility of each rider to ensure their life vest meets the following specifications:

1. It must float the rider
2. It must be constructed so as to provide adequate protection from impact damage to the ribs and internal organs.

4.3 Towlines

Riders must provide their own handles and ropes which must be of a non-stretch material.

4.4 Helmets

Riders must wear a suitable helmet if they choose to hit any of the obstacles in the wakeboard course. If a rider hits an obstacle during the competition, including practice, without a helmet, the rider will be disqualified from all of the competition. If a rider wishes to hit any obstacles, the rider must start the routine with a helmet on.

4.5 Damaged Equipment

A rider is fully responsible for his personal equipment. If a rider has damaged his equipment, he will have four minutes to repair the equipment. The Chief Judge will have the final say as to whether the equipment has failed. The damaged equipment can be repaired at the jetty only. It is the responsibility of the driver to go directly to the jetty. The time begins when the rider gets onto the jetty. The rider must have both feet back in his bindings before the 4 minutes elapses or his routine is over.

In the event that a rider realises his equipment has been damaged, the rider may throw the handle to indicate that he wishes to repair the equipment. This will, however, constitute one fall if it occurs in the wakeboard course. After the equipment has been repaired, the rider will resume his routine at the point where the handle was thrown. If a rider falls and then discovers that the equipment is damaged, the boat will resume the routine at the location of the fall after the equipment has been repaired.

5 RE-RIDES

It is the sole responsibility of the rider to ask for a rerun.

When unfair conditions occurs of artificial causes, which, in the opinion of the chief judge and a majority of the Boat Judges, adversely affects a rider, he shall be granted the option of a re-ride only on the pass affected. In case the unfair conditions occurs at an obstacle the rider will get a re-ride for that obstacle only and onwards. Re-rides will not be granted if a rider's personal equipment fails.

Re-rides must be taken immediately. If a rider is given a second re-ride, he may elect to take a five-minute rest, during which the next rider in order will perform his routine. The re-ride shall be taken at the conclusion of the rider's routine during which the five-minute rest period expires.

Requests for re-rides may be initiated by a Boat Judge for the event before the next rider starts or may be initiated, as soon as possible, by the rider or his team representative and shall be decided as soon as practicable thereafter. If, in the opinion of the Boat Judges for the event, the request was not initiated as soon as possible after the rider has ridden, the request shall be denied.

Re-ride requests will not be permitted if they are based on variations in weather or water conditions.

6 PROTESTS

Protests shall be made to the Chief Judge only by a team representative. Protest must be made in writing, must state the reason(s) for the protest, and must be filed as soon as possible, but no later than 10 minutes after the occurrence or after the results of the event are announced in case the protest is regarding the results.

Protests shall be allowed only for failure of the judges and calculators to comply with these rules and only if this non-compliance with rules have an adverse effect on a rider. No protests shall ever be permitted regarding the scoring by the Boat Judges.

A correction of an error in the computation of scores shall not be considered a protest and the correction shall be made on the approval of the Chief Judge and Calculator

within 10 minutes after the results are announced. It's up to the Chief Judge only to agree the inspection of scoring sheets

Protests must be accompanied by a protest fee of £50. This amount will be refunded if the protest is considered reasonable or upheld by the Judges.

7 USE OF VIDEO

Due to the subjective scoring nature & spirit of wakeboarding or wakeskating, video footage of any kind will not be used by Judges, riders or team representatives to resolve any disputes. Judges can only use the video footage before scoring a rider's routine.

8 COMPETITION FORMAT

8.1 General

Each rider shall be allowed two passes through the wakeboard course during which time the rider may perform any routine he or she chooses. The rider will be judged on three subjective style categories to arrive at a single combined score.

8.2 Judging of the routine begins

When the rider enters the wakeboard course and ends when the rider exits the wakeboard course, falls for the last time, or completes his/her double-up (finals only).

8.3 Boat (Scoring) Judges

The Chief Judge will designate three Boat Judges, to be seated in the tow boat, to score each rider's routine.

8.4 Scoring

Riders are encouraged to perform a smooth flowing routine with a wide variety of tricks. Each manoeuvre should be executed as cleanly as possible and taken to its limit.

Each one of the three boat judges should make notes of each rider's score in each score category on a scale from zero (0) to ten (10). A rider can get a minimum of 0.1 points.

Each score category represents the rider's performance on water as well as on obstacles when such are used.

8.4.1 Execution - 33.3 Points

This reflects the level of perfection to which each manoeuvre was performed, as well as the successful completion of the routine with a minimum number of falls.

8.4.2 Intensity - 33.4 Points

This reflects how big the moves were performed, as well as the technical difficulty of the tricks executed.

8.4.3 Composition - 33.3 Points

This reflects the overall composition of the routine in terms of the rider's ability to perform a variety of manoeuvres in a flowing, creative sequence

8.5 Calculation of Scores

The average method of calculating will be used. Scores from all categories (Execution, Intensity, and Composition) of a rider's routine are added together to produce a judge's total score. All three judges' total scores are then averaged to produce a final score for the rider on a scale from zero (0) to one hundred (100) that displays the overall impression of the routine performed.

All boat judges shall sign the calculated scores before they are made official.

The Calculator shall keep the original scoring sheets from all judges and all heats for at least six months after the end of the competition.

9 WAKEBOARD COURSE

9.1 Course Buoys

The Chief Judge will specify the buoys to be used for the wakeboard course.

9.2 Course Dimensions - Without Obstacles

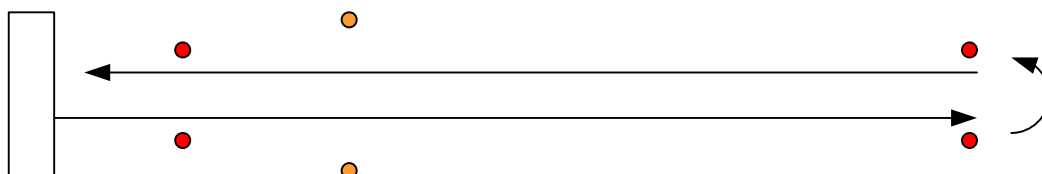

A pair of start buoys 10 metres apart shall establish the approximate area of the beginning of the wakeboard course from each direction. The end of the pass shall be signified by another pair of buoys 10 metres apart. The distance from the start and end buoys, will be approximately 370 metres (38 seconds at 35 km/hour or 22 miles/hour). These course dimensions will be used where practical. Bright orange buoys are recommended for the start and end buoys. A rider's first and second pass will begin after he or she rides around either the right or left hand start buoy. The affected pass will not be scored if the rider does not ride around the start buoy before his or her first or second pass.

9.3 Cut-Off Buoys

A pair of cut off buoys, approximately 50 metres apart, will indicate the point after which the tow boat will not be able to get up to speed for a rider to continue his run in the second pass. Bright green buoys will be used for the cut off buoy. The position of the cut off buoys will be determined by the Chief Judge and Chief Boat Driver.

9.4 Proceeding Through the Two Wakeboard Passes

On the first pass the boat shall follow as closely as possible the path specified by the Chief Judge for the event, such path to include the preparation time before each pass. On the second pass shall be in the opposite direction from the first pass.

9.5 Course Dimensions - With Obstacles

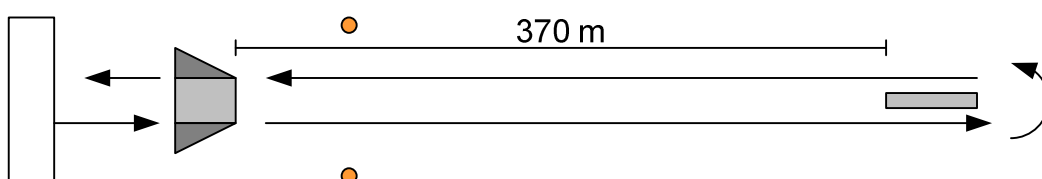

The end of an obstacle shall establish the approximate area of the beginning of the wakeboard course from each direction. The end of the pass shall be signified by the beginning of another obstacle. The distance between the start and end obstacles, will be approximately 370 metres (38 seconds at 35 km/hour or 22 miles/hour). These course dimensions will be used where practical.

9.6 Cut-Off buoy

A pair of cut off buoys, approximately 50 metres apart, will indicate the point after which the tow boat will not be able to get up to speed for a rider to continue his run in the second pass. Bright green buoys will be used for the cut off buoy. The position of the cut off buoys will be determined by the Chief Judge and Chief Boat Driver.

9.7 Proceeding through the two wakeboard passes

On the first pass the boat shall follow as closely as possible the path specified by the Chief Judge for the event, such path to include the preparation time before each pass. On the second pass shall be in the opposite direction from the first pass.

9.8 A rider's wakeboard pass will end

When he falls for the last time or when he passes the obstacle. A rider's last trick will be scored if he leaves the crest of the wake before passing the second obstacle.

Any rider who swims down the course to gain advantage over a fellow competitor will not be picked up. This will be the end of his or her routine.

10 DOUBLE-UP

By a majority of the judges the double-up for one or more categories may be cancelled completely if this should jeopardize the safety or the efficient running of the event.

Each rider who qualifies for the wakeboard finals will be given a double-up. It is the sole responsibility of each competitor to communicate to the driver before leaving the jetty whether he or she would like a left or right double-up. Re-rides will not be granted due to any miscommunication between the rider and driver. In the event that the boat provides a double-up in an incorrect direction, the rider must wave off the double-up and not attempt any manoeuvre. If any manoeuvre is attempted, which includes cutting at the wake, the rider will be deemed to have accepted his or her double up. If a rider waves off the double-up, the boat will then turn around, and proceed with a double-up in the correct direction. Re-rides will not be granted for turbulent water in this instance. However, if through driver error, then a 3 minute delay will be granted to the rider, to allow the water to calm back to suitable conditions.

In the final, if a rider's first fall occurs beyond the cut-off (3/4) buoys, the rider will have a double-up, but the rider will not be allowed to hit the obstacle at the end of the course, if any, for safety reason.

An unsuccessful double-up will not affect the score of a rider's routine. But a successful double-up will be counted as a bonus and will add to the rider's score.

11 OBSTACLES

There shall be a maximum of two different obstacles in a wakeboard course.

- Slider or rainbow slider
- Kicker

- Fun box

11.1 Rainbow Slider Or Flat Bar Slider:

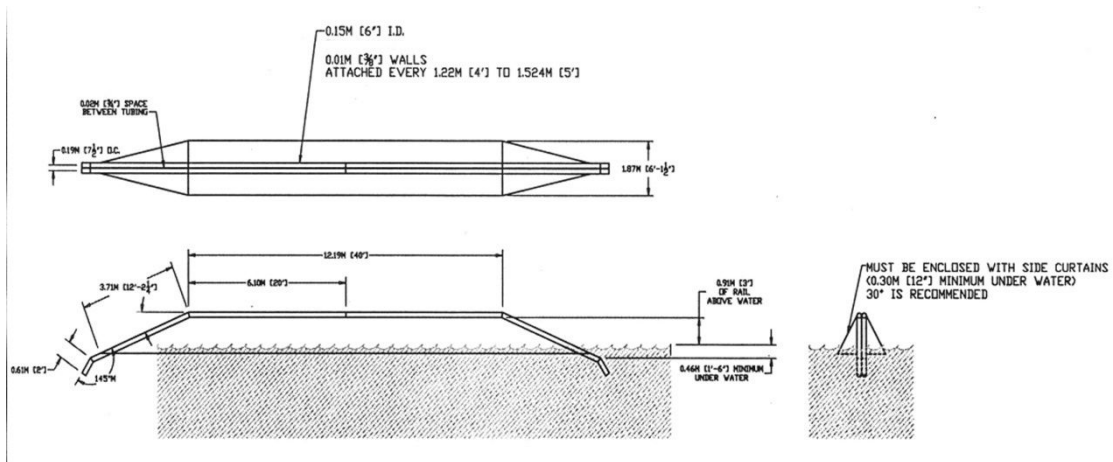

- Sliding surface: 2 x 0.15 metre inner dimension high density pyloethelene tubings or 0.20 – 0.30 metre flat bar.
- Height: From 0.70 metres to 0.90 metres
- Length of Flat Bed: From 10.00 metres to 12.00 metres
- Incline: From 12 degrees to 22 degrees

11.2 Kicker:

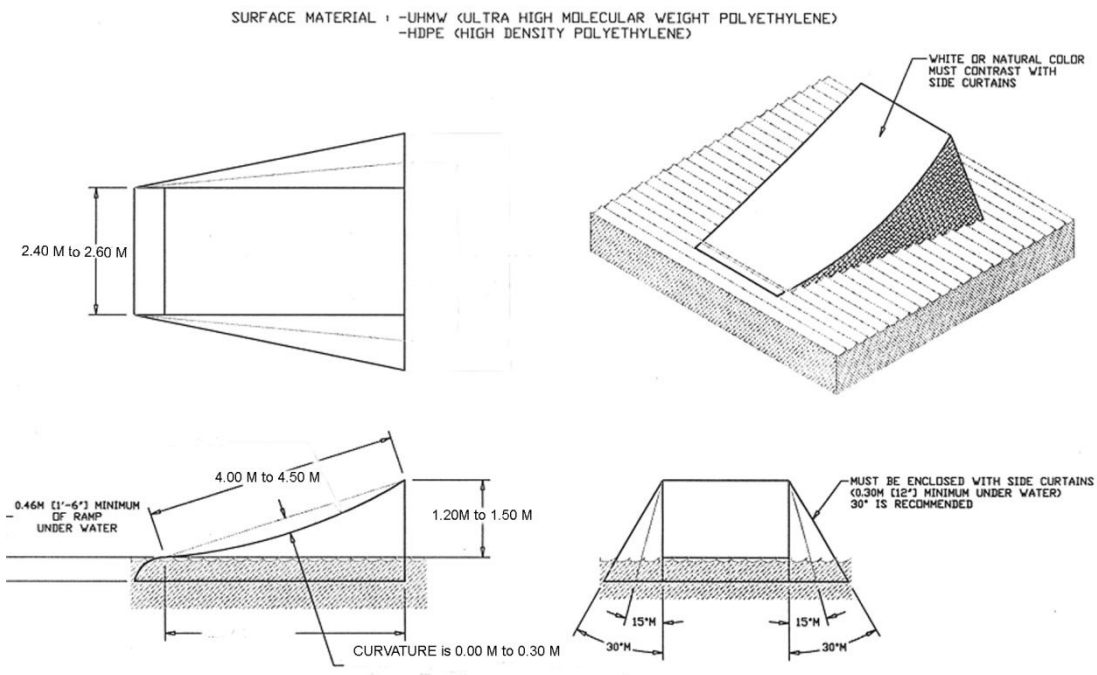

- Height: From 1.20 metres to 1.50 metres
- Length of Surface: 4.00 metres to 4.50 above waterline
- Width at All Points: 2.40 metres to 2.60 meters
- Curvature: 0.00 to 0.30 metre from straight line

11.3 Fun Box

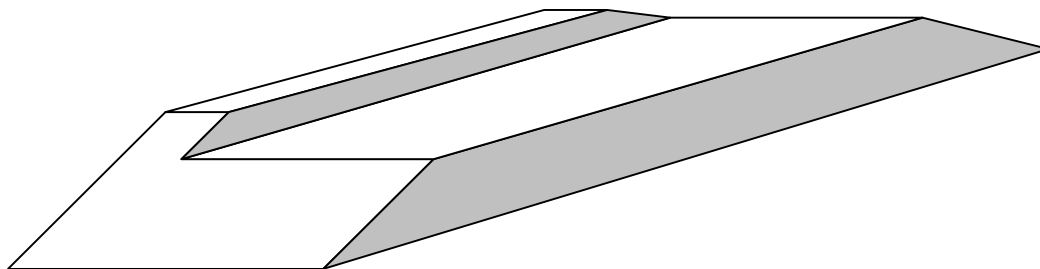

However, in certain cases, the Chief Judge with the majority of judges may make the decision where to place these obstacles in the wakeboard course. Riders are encouraged to hit these obstacles to add variation to their routines. Riders competing in all categories will be permitted to hit the obstacles.

It shall be possible for the organizer of an event to, after consultation with, and approval from the IWWF E&A Wakeboard Boat Council, to use additional or altered obstacles in the wakeboard course.

12 BOAT SPEED & ROPE LENGTH

Each rider shall receive his choice of a constant speed through the course for each pass, and preferred rope length. The boat speed, assuming it is held constant before entering the course, is the rider's responsibility. The rider is allowed to adjust the speed of the boat during the routine. The driver shall adjust the speed as quickly as possible after getting notice of the rider's sign.

The rider shall use the standardized signals and not cause the boat to stop, if possible. Deliberate use of delaying tactics will be considered unsportsmanlike conduct and will subject the rider to penalty or disqualification. The following signals apply in addition to well-known riding signals. Use in combination as applicable.

1. Thumb(s) up means go faster
2. Thumb(s) down means go slower
3. Pointing at an item of equipment means a problem with it
4. Pointing back toward object means debris in water
5. Raising hand overhead means request for re-ride
6. Fallen rider must signal to tow boat and safety boat that he/she is OK and/or injured.

It is the responsibility of the Rider to clearly communicating to the Officials in the boat or jetty marshal what rope length he or she desires. It may prove useful for the smooth running of the competition marking the correct rope length with a piece of tape or similar.

13 FALLS

13.1 Out-Of-Course Falls and Handle-Throw

A rider may have one out-of-course fall only before the start of his first pass.

The rider may also have one handle-throw before the start of his first pass which will also count as one out-of-course fall.

If a rider throws the handle prior to the start of his first pass to indicate that his rope was incorrectly put on the wrong loop by the officials or Judges in the boat, it will not count as an out-of-course fall.

An out-of-course fall or handle throw before the start of the second pass will count as one in-course fall.

In case of an out-of-course fall or handle throw before the start of a rider's first pass the boat will start again from the jetty.

Two falls: A rider may have a maximum of two falls during a routine. Should a fall occur, the boat will pick up the rider to proceed with the routine. The rider will not be picked up after a second fall.

13.2 Obstacles

When obstacles are used, a rider's pass will end when he or she has fallen either twice on the water or twice on the obstacles.

During qualifications, LCQ, and semifinal if a first fall occurs after the buoy the rider will not have any end obstacle.

13.3 Example One

A rider falls on a trick off the wake, and then falls on the slider, the rider will be picked up. But his pass will end if he falls on either an obstacle or water trick.

13.4 Example two

A rider falls off the rainbow slider, and then falls off the kicker but has no previous water falls. His pass ends.

13.5 Readiness

The rider must be ready to ride immediately upon the boat's return after the first fall, an out-of-course fall, or handle-throw.

14 HOMOLOGATION

14.1 General

A competition is homologated through the following steps:

1. The competition is announced to and sanctioned by the IWWF E&A Wakeboard Boat Council.
2. The competition is put on the official calendar at www.wakeboardcouncil.com.
3. The competition is run in accordance with these rules.
4. A homologation dossier, complete results for all heats, including qualification rounds, and a list of all participating riders including date of birth and nationality, is sent to the Wakeboard Boat Council as soon as possible after the completion of the competition, but at the end of September the same year at the latest.

Results from all homologated competitions will be included in the official IWWF E&A ranking for the same year.

Any sanctioned or homologated event, excluding the National Championships, open to international riders must be homologated as an international event to the IWWF E&A. If any international rider has competed at the National Championships, the rider has to be excluded from the results.

In addition, it is up to the Chairman of the Wakeboard Council to find other agreements.

15 REGISTRATION

All competitors must be members of British Waterski & Wakeboard Federation or Wakeboard UK. A competitor must be able to prove his or her membership. Prior to competing, a competitor must sign a participation contract and understand the nature of the sport and its special risks, particularly in the format. It is the responsibility of the competitor to register with the designated registration person and show proof of Federation membership before riding. Competitors must disclose to the event organiser any special medical conditions, including but not limited to, injuries in the past or present or other pre-existing medical conditions. A document may be sign by all riders at the registration.

16 OFFICIALS

The minimum number of officials in the panel at a competition are:

- Chief Judge
- 2 Assistant Judges
- Calculator
- Boat Driver
- Jetty Marshall